

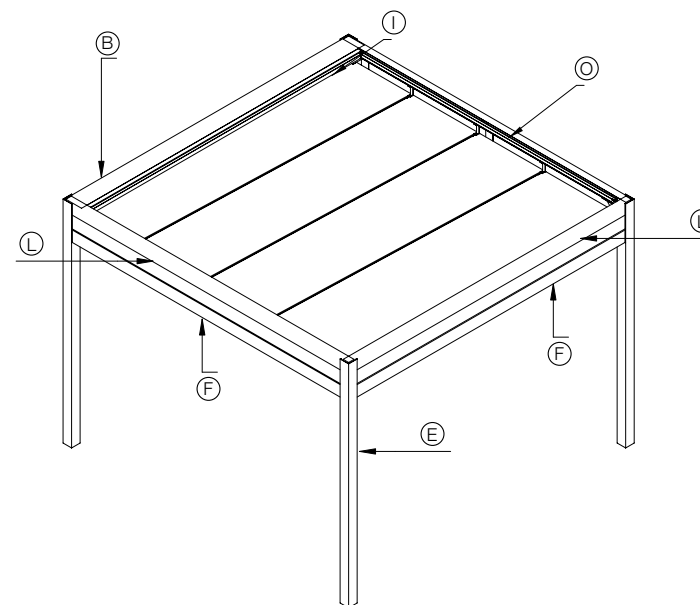



COLORI STANDARD — STANDARD COLORS



 Struttura ombreggiante autoportante in alluminio con tenda richiudibile ad impacchettamento, formata da un telo (teso quando aperta) fissato ad un sistema di traversi, carrelli e guide che ne permettono lo scorrimento orizzontale. Resistenza al vento garantita fino alla classe 6 secondo la UNI EN PR 13561. Su richiesta è possibile installare il sistema antigoccia per la protezione dalla pioggia. Non si garantisce la tenuta al carico di neve. La formazione di condensa sul telo non è da considerarsi difetto, si tratta di un fenomeno naturale. In presenza di forti piogge o piogge accompagnata da vento non è garantita la completa impermeabilità alla pioggia.

B Comando di movimentazione elettrico
I Traversa supporto motore
O Guida di scorrimento
F Trave frontale
E Pilastro
L Pannello di tamponamento perimetrale

 Aluminium shading free-standing structure with packaging retractable awning, in fabric made (tight when opened) fixed to crossbar profiles, trolleys and guides system, which permit the horizontal slide. Wind resistance guarantee up to class 6 according UNI EN PR 13561. On request it is possible to install the antidrop system for the rain protection. The resistance under snow weight is not guarantee. The development of condensation on the fabric is natural and not to be considered as a defect. In case of heavy rains or rain combined with strong wind is not guaranteed complete impermeability to rain.

B Moving electrical control
I Supporting motor crossbar profile
O Sliding guide
F Frontal girder
E Pilar
L Cover metal foil

 Das selbsttragende Beschattungssystem aus Aluminium mit faltbarem Tuch (bei der ÖFFNUNG gespannt), besteht aus einem Tuch auf Laufschiene befestigt, durch Seitenrollen Waagrecht Beweglich. Windbeständigkeit bis Klasse 6 nach UNI EN PR 13561 garantiert. Optional ist auch die Wasserdichtung erhältlich. Das Gestell ist gegen Schneelast nicht garantiert. Die Entwicklung von Kondensation auf den Stoff ist nicht ein Defekt, sondern ist natürlich. Wenn es sehr stark regnet, oder regnet mit sehr viel Wind, ist die Wasserundurchlässigkeit der Struktur nicht garantiert.

B Elektrische Bedienung
I Querträgerbalken für den Motor
O Laufschiene
F Frontbalken
E Pfosten
L Abdeckblech

 Structure pergola en aluminium avec toile rétractable par empaquetement. Formée d'une toile (tendue une fois ouverte) reliée à un système composé de traverses, de chariots, et de coulisses qui permettent un déplacement horizontal de la toile. Résistance au vent garantie jusqu'à la classe 6 selon la norme UNI EN PR 13561. Sur demande, il est possible d'intégrer le système antigoutte pour une protection de la pluie. Aucune garantie pour la tenue à la neige. Le développement de condensation sur le tissu n'est pas considéré un défaut, c'est un phénomène naturel. En présence de fortes averses ou de pluie accompagnée de vent, la complète étanchéité à la pluie n'est pas garantie.

B Commande pour le manoeuvre électrique
I Profil de traverse support moteur
O Glissière pour le glissement
F Poutre frontale
E Pilier
L Ceinture perimetrale

 Estructura de protección solar autoportante en aluminio con toldo de cierre por empaquetamiento, formada por un tejido (tenso cuando está abierto) fijado a un sistema de palillos, carritos y guías que le permiten el deslizamiento horizontal. Resistencia al viento garantizada hasta la clase 6 según la UNE EN PR 13561. Sobre pedido es posible instalar el sistema antigota para la protección de la lluvia. No se garantiza la resistencia a la carga de nieve. La formación de agua de condensación no es un defecto sino un fenómeno natural. En presencia de fuertes lluvias o lluvia acompañada de viento no esta garantizada la completa impermeabilidad al agua.

B Mando de movimiento eléctrico
I Perfil transversal soporte motor
O Guía de desplazamiento
F Viga frontal
E Pie
L Perfil de tapadura perimetral



Schema tecnico generale/General technical plan/Allgemein-technisches Schema/Plan technique général/Dibujo tecnico general

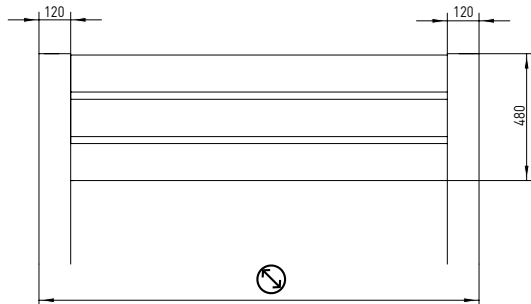

Larghezza interasse guide/Guides interaxis width/Breite des Achsabstandes der Führungsschienen/Largeur entraxe coulisses/Linea guía intereje

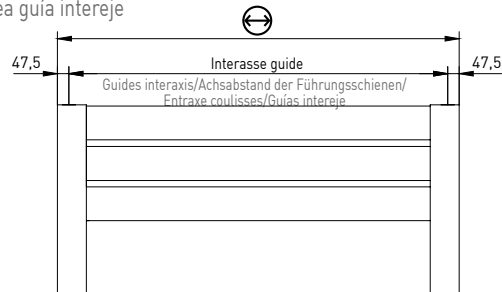

Dimensioni profili/Profiles dimensions/Profilabmessungen/Mesures profils/Dimensiones perfiles

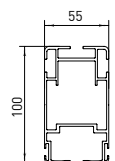

Guida
Guide
Führungsschiene
Glissière
Guía

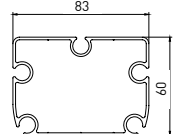

Terminale
Terminal bar profile
Fallstange
Barre de charge
Terminal

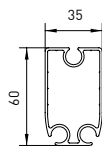

Traverse
Porta Tessuto
Fabric carrying
Crossbar profile
Stoffquerträger
Profil de traverse
porte tissu
Palillo



Sezione travi/Girder section/Balkenquerschnitt/Section poutres/Sección viga

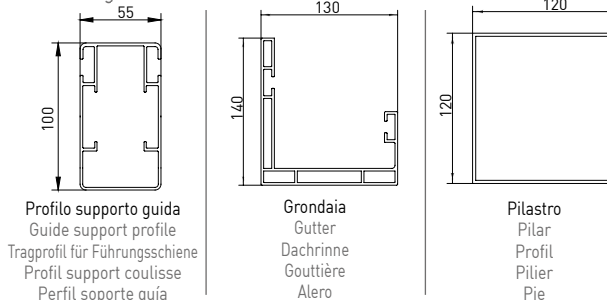

Profilo supporto guida
Guide support profile
Tragprofil für Führungsschiene
Profil support coulisse
Perfil soporte guía

Grondaia
Gutter
Dachrinne
Gouttière
Alero

Pilastro
Pilar
Profil
Pilier
Pie



Attacchi a terra GENNIUS
Gennius ground connection
Gennius Bodenbefestigung
Support fixation sol Gennius
Sujeción a suelo Gennius

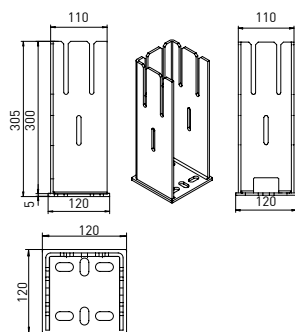

Piastra a terra per piedino
Ground connection
Fussbodenplatte
Platine au sol pour pied
Placa de suelo para cubre pie

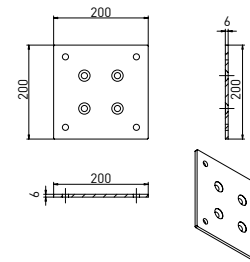

Applicazione guide
Guides installation
Führung-Montage
Application coulisse
Aplicación guías

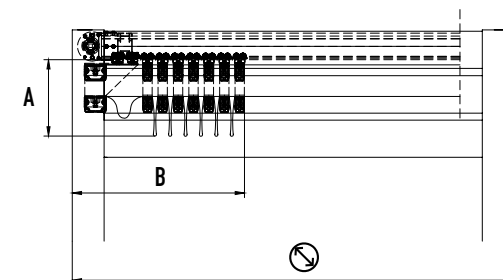
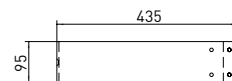

Valori indicativi degli ingombri del telo e del numero di traversi portatelo.
Indicative values of the fabric encumbrance and the number of the fabric carrying crossbar profiles.
Richtwerte der Ausmaße des Tuches und der Anzahl der Stoffquerträger
Valeurs indicatives des encombrements de la toile et du nombre de profils de traverse porte tissu.
Valores indicativos de las dimensiones del tejido y del número de palillos.

	A cm	B cm	N
200	29	63	5
250	29	69	6
300	29	80	8
350	29	86	9
400	29	92	10
450	29	98	11
500	29	109	13
550	29	115	14
600	29	121	15
650	29	127	16
700	29	138	18
750	29	144	19
800	29	150	20
850	29	156	21
900	29	167	23
950	29	173	24
1000	29	179	25

N Numero traversi (compreso terminali). Misura massima interasse traversi portatelo 40 cm.
N Crossbar profile numbers (terminals included). Maximum interaxis fabric carrying cross bar profiles measure cm 40.
N Anzahl der Querträger (inklusive Fallstangen). Maximaler Achsabstand der Stofftragerschienen cm 40.
N Nombre profils de traverse (compris barres de charge). Mesure maximale entraxe profils traverse porte tissu cm 40.
N Numero de perfiles transversales (terminales incluidos). Medida máxima intereje perfiles transversales para lona cm 40.